



MARINE PRODUCTS

Anchor Selection



Optimum design of an anchor is influenced by the specific composition of the ocean floor. Basically, we categorize the ocean bottoms into three groups:

1. Mud, or silt, which varies the most in consistency and offers little resistance to forces.
2. Sand, ideally the most consistent, and where anchors specifically designed, reach excellent holding efficiency.
3. Rock, or Marl, poor holding ground where an anchor's dead weight is its only asset.

The efficiency of an anchor in a given test is expressed in terms of "Holding Power" per pound of its own weight, not in "Proof test" which indicates physical properties of the material.

The fluke angle of an anchor has a definite effect upon the "Holding Power." The flukes should enter the bottom at an angle that will allow the crown, or head, to penetrate to a depth which can produce maximum efficiency: Additionally, we have determined the following:

1. The angle of fluke penetration in mud bottoms should approximate 50° .
2. In sand the penetration angle should be in the area of 30° .
3. For anchoring in various bottoms a compromise approximating 43° is desirable.

Other considerations in selecting an anchor should include:

1. Convenience for handling and stowing.
2. Aptitude for taking hold.
3. Physical strength.
4. Freedom from fouling, which all anchors do, but

some in lesser degrees.

5. Influence developed by the chain's catenary, which absorbs shock loads, and lowers the angle of pull at the anchor by its weight.

The anchor is the key to effective anchoring or mooring. It is essential to know what to expect from various anchors. The resistance of an anchor to being dragged through a soil has been considered as occurring in two stages: first, biting into the bottom due to the ploughing effect of the flukes, and secondly, maintaining a continuous resistance to drag after it is planted into the bottom.

Holding power is directly proportional to projected fluke area, and shear strength of the bottom materials, and inversely proportional to penetration-area resistance. In many cases a smaller anchor with favorable fluke area to weight ratio is more dependable than a heavier anchor.

Holding Power for the two most widely used anchors are as follows:

1. Stockless Type anchors in sand develop a holding power to weight ratio of seven to one. In mud it develops three to one. The angle of penetration in both cases is 45° .
2. Lightweight type anchors in sand develop a holding power to weight ratio of twenty to one, with the angle of penetration being 30° . In mud it develops nine to one with the angle of penetration being 50° .

The depth of penetration in all preceding cases is compiled from three to seven feet in sand, and from seventeen to twenty feet in mud. All calculations incorporate a 0° scope angle.



Stockless Type Anchors



Anchor Weight	A	B	C	D	E	F	G	H	J	Proof Test
200	27	18	9-1/2	15-1/8	5-1/8	5-1/2	1	5	4	8300
300	32	23-1/4	11-11/16	17-3/16	6-11/16	5-1/2	1	5	4-1/2	10900
400	32	25-3/4	13	19	7	5-1/2	1	5	4-1/2	13000
500	35	26-1/2	14	20	7	7	1-1/4	6	5-1/2	15000
700	38	29-1/2	15-5/8	23-1/2	8-1/8	7	1-1/4	6	5-3/4	18700
775	38	32	16-7/8	24-3/4	8-5/8	7	1-1/4	6	5-3/4	20050
900	42	32	17	24	9	7-1/2	1-1/2	6-1/2	6-1/2	22300
1000	42	33-5/8	18	25-1/8	9-3/4	7-1/2	1-1/2	6-1/2	6-1/2	24100
1260	46	36-3/8	18-3/4	28-3/8	9-7/8	8-1/2	1-3/4	7-1/2	6-3/4	28800
1430	49	39	20	28-7/8	10-3/4	9-3/4	2	8-1/2	7	31700
1540	49	40	20-1/2	30-1/2	11	9-3/4	2	8-1/2	7	33600
1600	49	40	20-1/2	30-1/2	11	9-3/4	2	8-1/2	7	34600
1750	52	41-1/2	21	33-1/4	11-3/8	9-3/4	2	8-1/2	7-1/4	37150
1875	52	43	22	34-3/4	12	9-3/4	2	8-1/2	7-1/4	38400
1950	52	43	22	34-3/4	12	9-3/4	2	8-1/2	7-1/4	40550
2100	58	44-3/4	23	33-3/8	12-1/8	9-3/4	2	8-1/8	7-1/2	43050
2500	58	44-3/4	23-1/4	33-3/8	12-1/8	9-3/4	2	8-1/2	7-1/2	49650
2800	58	48	25	35-7/8	13	9-3/4	2	8-1/2	7-1/2	54500
3000	64	47	25-1/2	36	12-3/4	12	2-1/2	10	8-3/4	57700
3500	64	52-3/4	27-1/2	39-1/2	14-1/4	12	2-1/2	10	8-3/4	65200
4000	70-5/8	53-1/4	27-1/2	39-1/4	14-1/2	12	2-1/2	10	9-1/2	72600
4500	70-5/8	56-3/4	29	42	15	12	2-1/2	10	9-1/2	79700
5000	76	57-1/2	30	42	15-5/8	15	3	12	10-1/4	86500
6000	76	63-1/2	33-1/4	47	17-1/4	15	3	12	10-1/4	99100

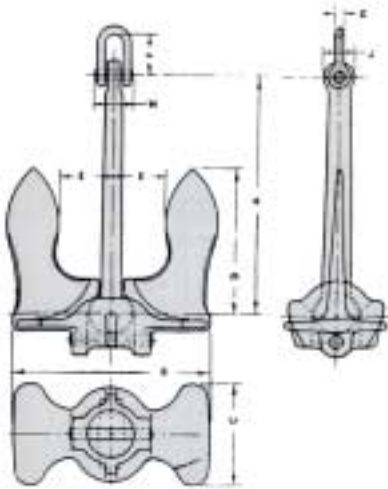

Anchor Weight	A	B	C	D	E	F	G	H	J	Proof Test
6300	76	63-1/2	33-1/4	47	17-1/4	15	3	12	10-1/4	102700
6500	82	63-1/2	33	47-5/8	17-1/4	15	3	12	10-3/4	105100
6750	82	65	33-3/4	48-3/4	17-5/8	15	3	12	10-3/4	107900
7000	82	66-5/8	34-3/4	49-3/4	18	15	3	12	10-3/4	110700
7600	82	67-1/2	34-3/4	49-3/4	18-3/8	15	3	12	10-3/4	117300
8100	93-1/2	66-1/4	34-1/4	48-7/8	18-1/4	17	3-1/2	13-1/4	11-1/2	122500
8600	93-1/2	68-1/2	35-3/4	50-1/2	18-1/2	17	3-1/2	13-1/4	11-1/2	127500
9000	96	70-1/4	36-3/8	51-3/4	19-1/8	17	3-1/2	13-1/4	11-1/2	131400
10000	96	75-1/2	39	58	21	19	4	14-3/4	12	140400
11000	96	75-1/2	39	58	21	19	4	14-3/4	12	148500
12000	96	76-3/4	40	58	20-3/4	19	4	14-3/4	12	156100
13000	98	76-3/4	40	58	20-3/4	19	4	14-3/4	12	163500
14000	103	80-1/2	44	60	22-1/4	19	4	14-3/4	13	170500
15000	103	86	46	65	24	19	4	14-3/4	13	176800
16000	108	86	46	65	24	19	4	14-3/4	13	182800
18000	112	88-1/4	48-1/4	65-5/8	24-3/4	22	4-1/2	16-3/4	13	194200
18900	112	88-1/4	48-1/4	65-5/8	24-3/4	22	4-1/2	16-3/4	13	198800
20000	112	96	50	72	26	22	4-1/2	16-3/4	14	204300
25000	120	103	53-3/4	77-1/2	28	22	4-1/2	16-3/4	15	227000
30000	128	110	57-1/4	82-1/2	29-7/8	24	5	18-3/4	16	247600
35000	135	116	60	87	31-1/2	25	5	19	17	265600
40000	140	121	63	91	32	26	5-1/2	20	17-1/2	278200
45000	147	126	65	94	34	27	5-1/2	21	18	287550
50000	152	131	68	99	35	28	6	21-1/2	19	292600

INTERMEDIATE SIZES AVAILABLE UPON REQUEST



Lightweight Type Anchors

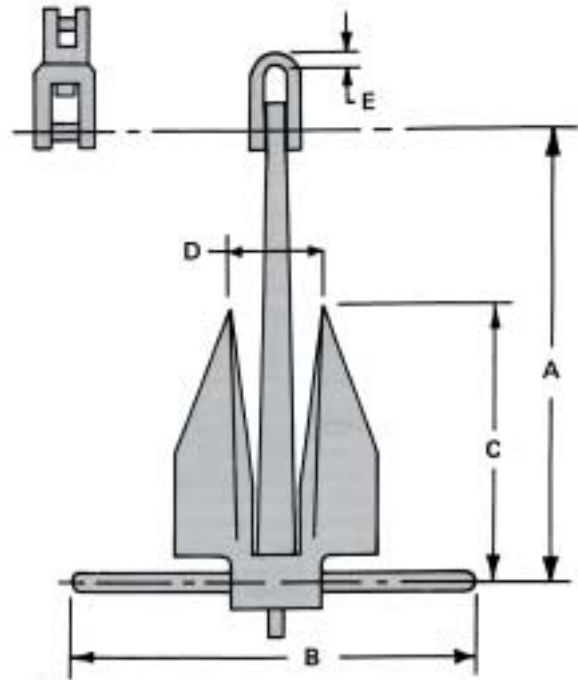

Anchor Weight	A	B	C	D	E	Proof Test
8	20	19	11-1/2	1-1/2	3/8	300
16	25	23-3/4	14-1/2	1-7/8	1/2	560
30	30-1/4	28-3/4	17-1/2	1-7/8	1/2	1000
50	34-3/4	33	20	2-3/8	5/8	1500
75	38	36	22	2-1/2	3/4	2070
100	41-1/2	39-1/2	24	3-3/8	7/8	2608
150	46-3/4	44-1/2	27	4	7/8	4200
200	52-1/2	45-1/2	33	6-1/8	7/8	10100
300	56	48-1/2	36-3/4	13-1/2	1-1/8	13000
500	63	54-1/2	39-3/4	15-1/8	1-1/2	18300
750	67-1/2	58-1/2	44-11/16	16-1/2	1-1/2	24100
1000	72	62	45-3/8	18-3/4	2	30000
1500	77	70-7/8	51-3/16	19-3/8	2	41000
2000	83	71-3/4	52	22-5/8	2-1/2	52500
2500	89	84-1/2	59	13-7/8	2-1/2	62500
3000	94	89	59	14-3/8	3	72500
4000	104	98-3/4	65-1/2	15-3/8	3	90500
5000	112	106-1/2	70-1/2	18	3-3/8	105500
6000	118	112	74	18-5/8	3-3/4	121500

Anchor Weight	A	B	C	D	E	Proof Test
8000	129	122-1/2	77-3/8	20-1/4	4-1/8	145500
10000	138	131	87	21-7/8	4-1/2	165500
12000	145	145	91	23	4-3/4	183000
14000	152	152	95-3/4	24	5	198000
16000	160	160	101	25-1/4	5-1/4	210000
20000	172	163	108-3/8	27-1/4	5-5/8	233000
30000	197	187	112	31-1/4	6-1/2	278000
35000	207	196	118	33	6-1/2	289500
40000	216	205	123	34-1/2	7	296000
50000	232	222	133	37-1/2	7-1/2	309500
60000	246	235	141	40	7-1/2	321000
70000	258	247	148	42	8	336000
80000	271	259	156	44	8	349400
90000	282	269	162	46	8-1/2	362900
100000	293	280	168	48	8-1/2	376000